



CLIMATECARE

14.5+ SEER Air Conditioners

TCGF Features:

- *Very Small Square Footprint, fits where most competitive models can't*
- *Energy Star Rated*
- *Environmentally Friendly R410a Refrigerant - delivers environmentally friendly performance with zero ozone depletion.*
- *Pre-painted steel cabinet with special primer formulas for better paint to steel bond and ensures less fading when exposed to sunlight*
- *Scroll Compressor protected with high pressure relief and temperature sensor for added longevity*
- *High Grade Wire Coil Guard and heavy duty black polymer mesh for extra protection.*
- *Solid Core Liquid line filter drier removes any contaminants for added Compressor protection*
- *Swept Wing Fan Design & Compressor blanket for quiet operation*
- *Sound Isolated motor & Rigid Top panel for quieter air flow pattern*
- *Cushioned compressor mounts to dampen vibrations*
- *"MicroChannel" technology for superior efficiency and longer lifetime reliability*
- *Standard 5 year parts warranty, but if registered online within 90 days of purchase upgrades to 10 year total parts warranty.*



Unit Size	Sound Rating (dB)	Aprox. Wgt. (Lbs)	SEER*
2.0 TON	73	128	14.5 – 16.0
2.5 TON	72	101	14.5 – 16.0
3.0 TON	71	145	14.5 – 16.0
3.5 TON	78	172	14.5 – 16.0
4.0 TON	77	180	14.5 – 16.0
5.0 TON	75	199	14.5 – 15.0

* Efficiency will vary based on indoor and/or coil/air handler/furnace match up.
Subject to change without notice.

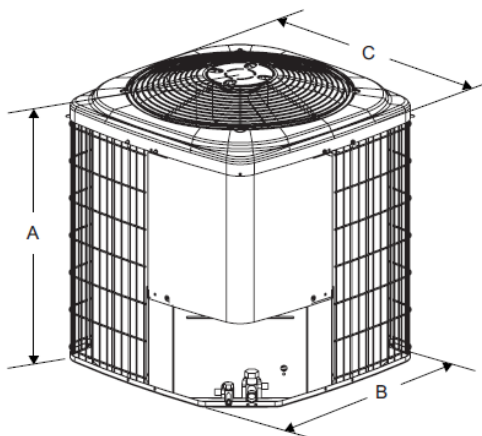

All dimensions are in inches. They are subject to change without notice. Certified dimensions will be provided upon request.

Unit Model	Dimensions (Inches)			Refrigerant Connection Service Valve Size	
	A ¹	B	C	Liquid	Vapor
24	28	29	29	3/8"	3/4"
30	36	29	29		
36	36	29	29		
42	34	33.6	33.6		7/8"
48	36	33.6	33.6		
60	40	33.6	33.6		

1. Including Fan Guard.
2. Adapter fitting required for 1-1/8" line set.

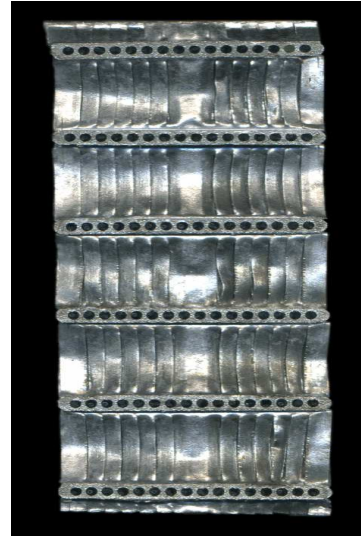
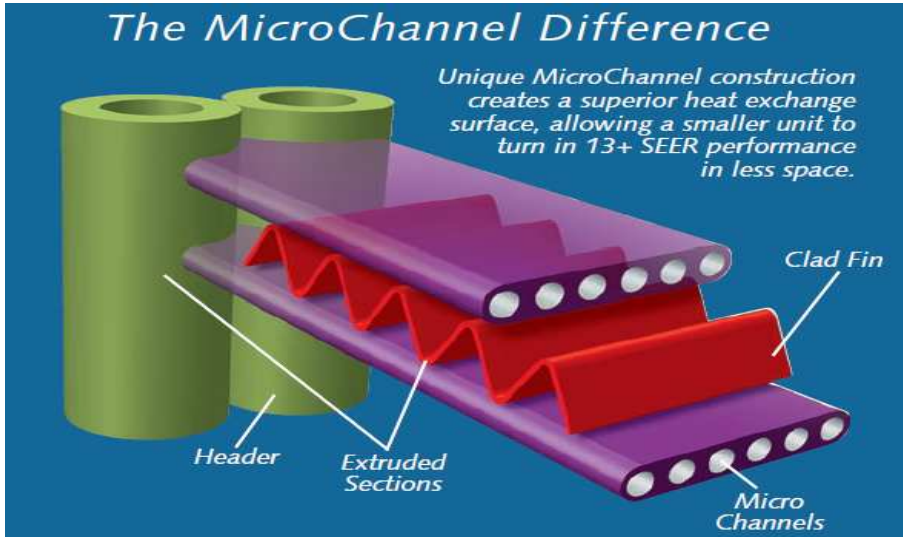

Benefits of Microchannel Technology

1. **Improved Heat Transfer Properties**
 - a. Traditional tube and fin designs use the expansion of copper tubes to join the aluminum fins, possibly resulting in inconsistent joints. Microchannel coils are bonded by brazing the fins directly to the tubes, eliminating the possibility for air gaps and significantly improving heat conduction.
 - b. Microchannel coils segment each tube into 17 micro Circuits as opposed to one large round tube with minor tube enhancements, such as rifling.
2. **Smaller Size & Weight**
 - a. As a result of the improved thermal performance found in the Microchannel coil, size and weight can be significantly reduced.
 - b. This results in a smaller overall product in size and weight and greater flexibility in your home landscaping design.
3. **Reduced Refrigerant Charge**
 - a. Microchannel coil design is so efficient that refrigerant charge is reduced by up to 50% when compared to an equivalent Tube and Fin residential split system design.
 - b. Less Refrigerant Is Better for the Environment. Aids In Environmental Responsibility and Sustainability for today and generations to come.
4. **Improved Durability and Serviceability**
 - a. Durable cast aluminum design provides excellent efficiency and robustness not previously available in traditional aluminum coils designs
 - b. Can clean with medium-pressure water (garden hose with spray nozzle).
5. **Improved Corrosion Protection**
 - a. Conventional copper tube/aluminum fin coils are predisposed to galvanic corrosion (2 dissimilar materials).
 - b. Testing with microchannel coils has resulted in corrosion resistance that is seven times greater than that found in traditional Tube/Fin coils.



Conventional coil 1000 hour Test



Microchannel coil 7000 hour Test