



CLIMATECARE

14.5+ SEER Heat Pumps

THGF Features:

- *Slimmer footprint, fits most landscaping designs*
- *Energy Star Rated*
- *Efficiency ratings of up to 15+ SEER & 9.0 HSPF when matched with Variable Speed Indoor Section*
- *Environmentally friendly R410a Refrigerant*
- *Pre-painted steel cabinet with special primer formulas for better paint to steel bond and ensures less fading when exposed to sunlight*
- *Scroll compressor protected with high pressure relief and temperature sensor for added longevity*
- *High Grade Wire Coil Guard and heavy duty black polymer mesh for extra protection.*
- *Solid Core Liquid line filter drier removes any contaminants for added Compressor protection*
- *Swept Wing Fan Design & Compressor blanket for quiet operation*
- *Cushioned compressor mounts to dampen vibrations*
- *Quality copper tube/aluminum fin construction for reliability*
- *Standard 5 year parts warranty, but if registered online within 90 days of purchase upgrades to 10 year total parts warranty*



You can choose a THGF Heat Pump as part of your Hybrid Comfort System that lets you shift from the efficiency of an electric Heat Pump to the added power of a high efficiency gas furnace for the most efficient heating you've ever experienced

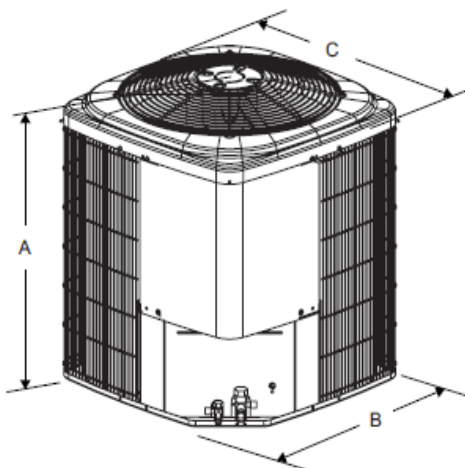

All dimensions are in inches. They are subject to change without notice. Certified dimensions will be provided upon request.

Unit Model	Dimensions (Inches)			Refrigerant Connection Service Valve Size	
	A ¹	B	C	Liquid	Vapor
18	28	34	34	3/8"	3/4"
24	40	29	29		
30	40	34	34		
36	40	34	34		
42	40	34	34		
48	40	34	34	7/8"	
60	40	34	34		

1. Including Fan Guard.